



outdoor living spaces

www.gardenhideouts.co.uk



Classic Pod

3mtr x 4.76mtr
from £18,950

4mtr x 4.76mtr
from £20,950

Available unfurnished from £14,950

Derby Office
Mercia Marina, Findern Lane, Willington,
Derbyshire DE65 6DW
t: 01283 707357

Hanbury Office
Hanbury Wharf, Hanbury Road, Droitwich,
Worcester WR9 7DU
t: 01905 794445

Classic Pod

The Classic Pod from Garden Hideouts is a brilliantly versatile space for living, sleeping, entertaining or relaxing. With a dining area that quickly converts to a comfortable double bed, it is a multiple use environment that adapts beautifully to your needs.

The use of oak veneers and creative lighting creates a warm, inviting space and the ecclesiastical style window that matches the front doors brings a classic appearance to the whole interior. With other luxuries such as a corner basin, high quality laminated flooring and display shelves, this is a room in the garden that's quite simply a home from home.

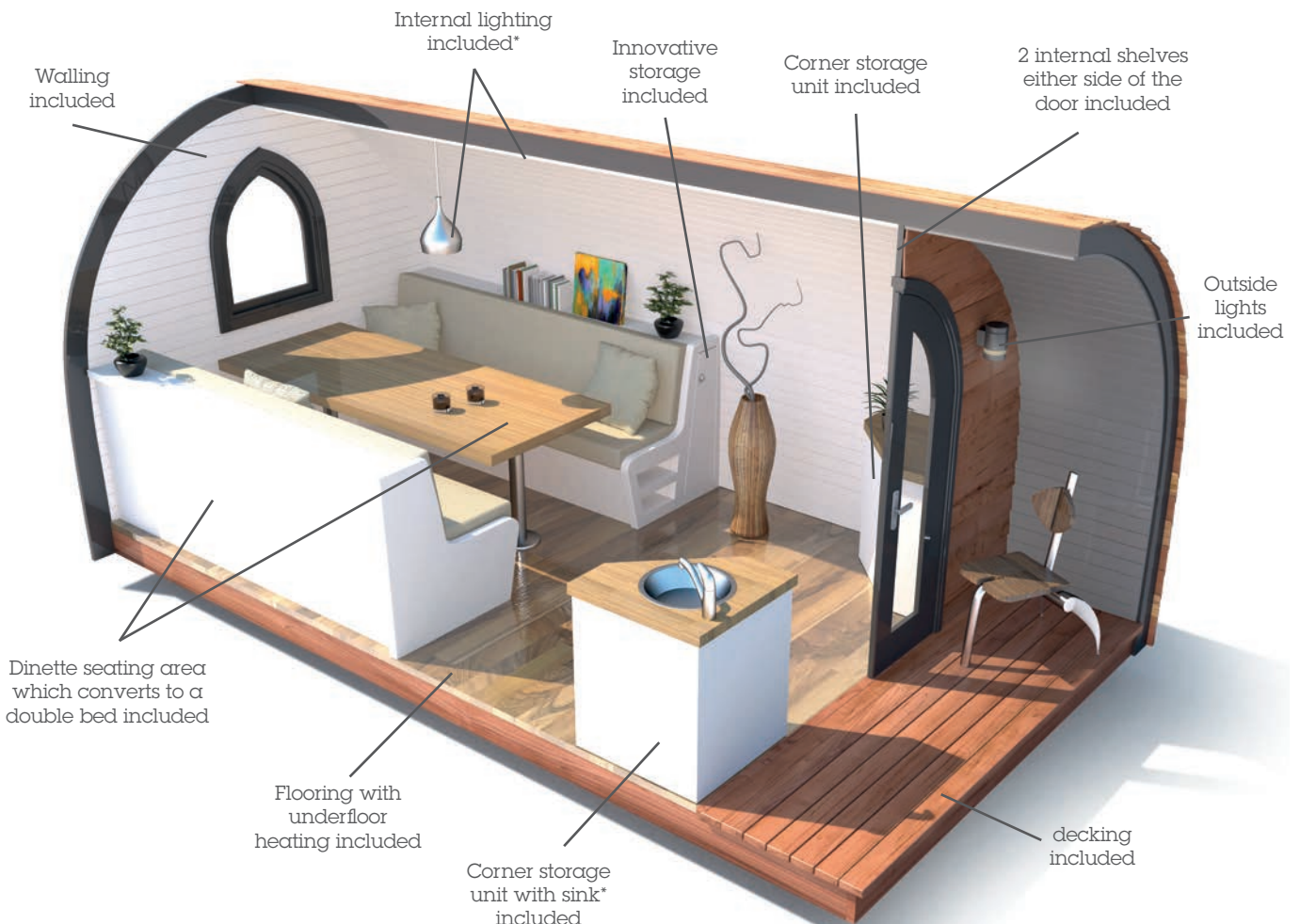

3mtr x 4.76mtr
from £18,950

4mtr x 4.76mtr
from £20,950

Available unfurnished from £14,950

*Examples shown for visual purposes only.

3mtr Plans

External

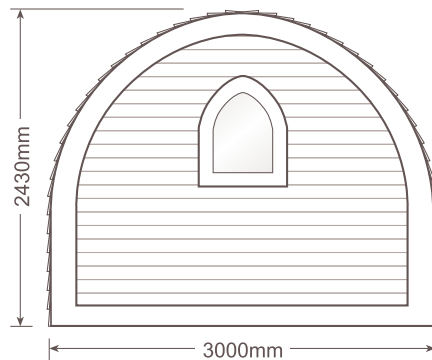
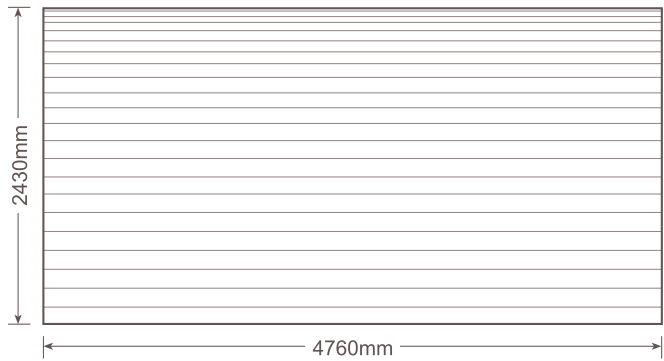
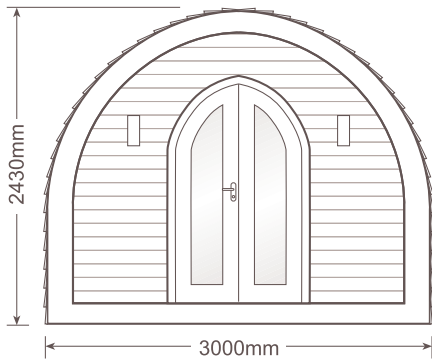

Dimensions*

External Width: 3000mm Internal Width: 2720mm
External Length: 4760mm Internal Length: 3440mm
External Height: 2430mm Internal Height: 2160mm

External Deck Area: 900mm x 2760mm
Door Dimensions: 1760mm x 1000mm
Window Dimensions: 850mm x 680mm

Internal Floor Area: 9.96m²

Internal

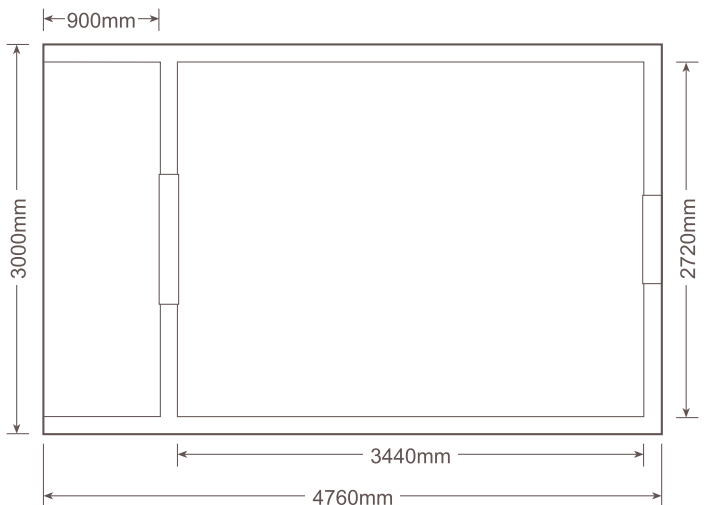
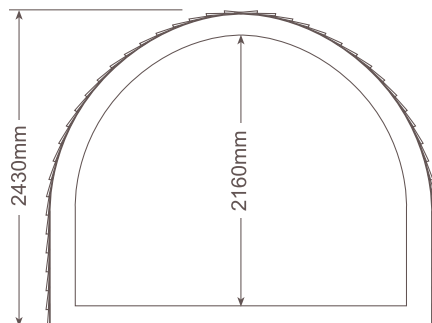

*Sizes are approximate, as these are hand crafted products measurements may vary.

4mtr Plans

External

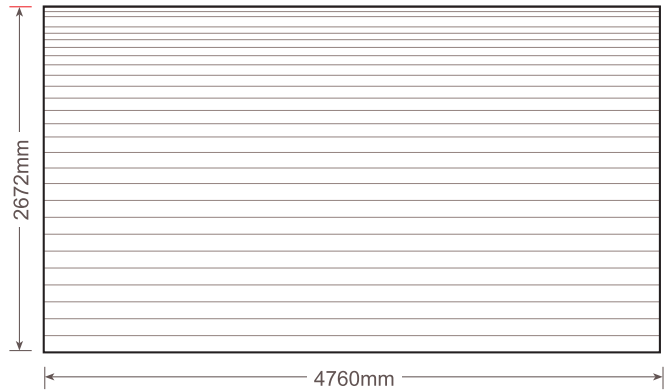
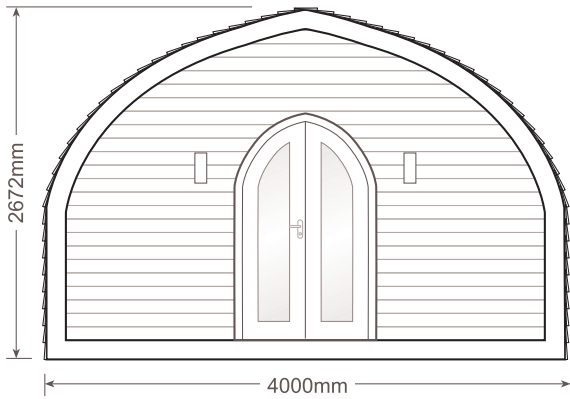

Dimensions*

External Width: 4000mm Internal Width: 3720mm
External Length: 4760mm Internal Length: 3440mm
External Height: 2672mm Internal Height: 2402mm

External Deck Area: 900mm x 3760mm
Door Dimensions: 1760mm x 1000mm
Window Dimensions: 1350mm x 3500mm

Internal Floor Area: 12.80m²

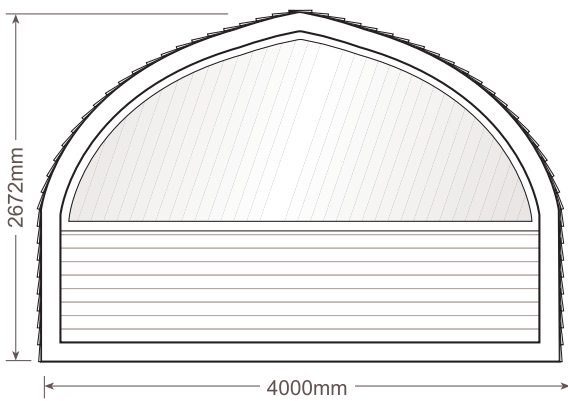

Internal

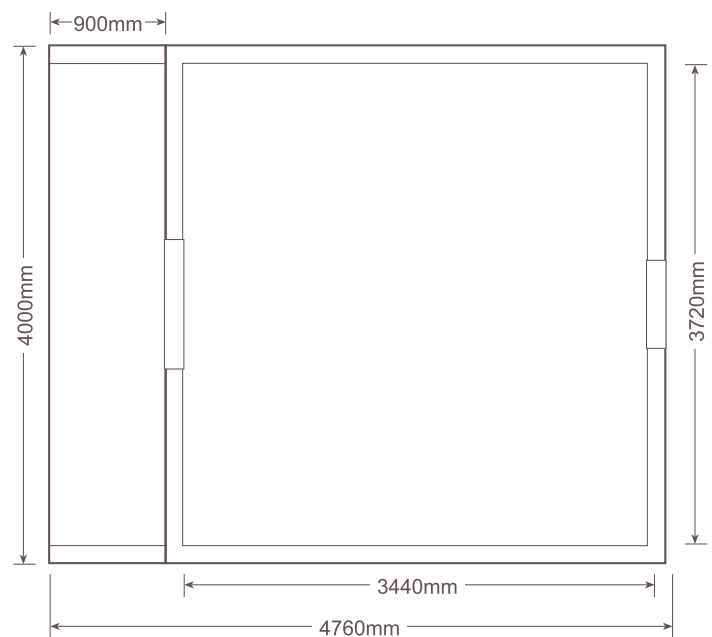
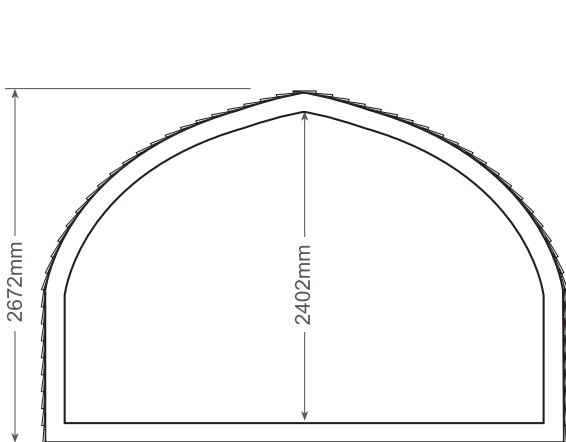

*Sizes are approximate, as these are hand crafted products measurements may vary.

Technical - Walls

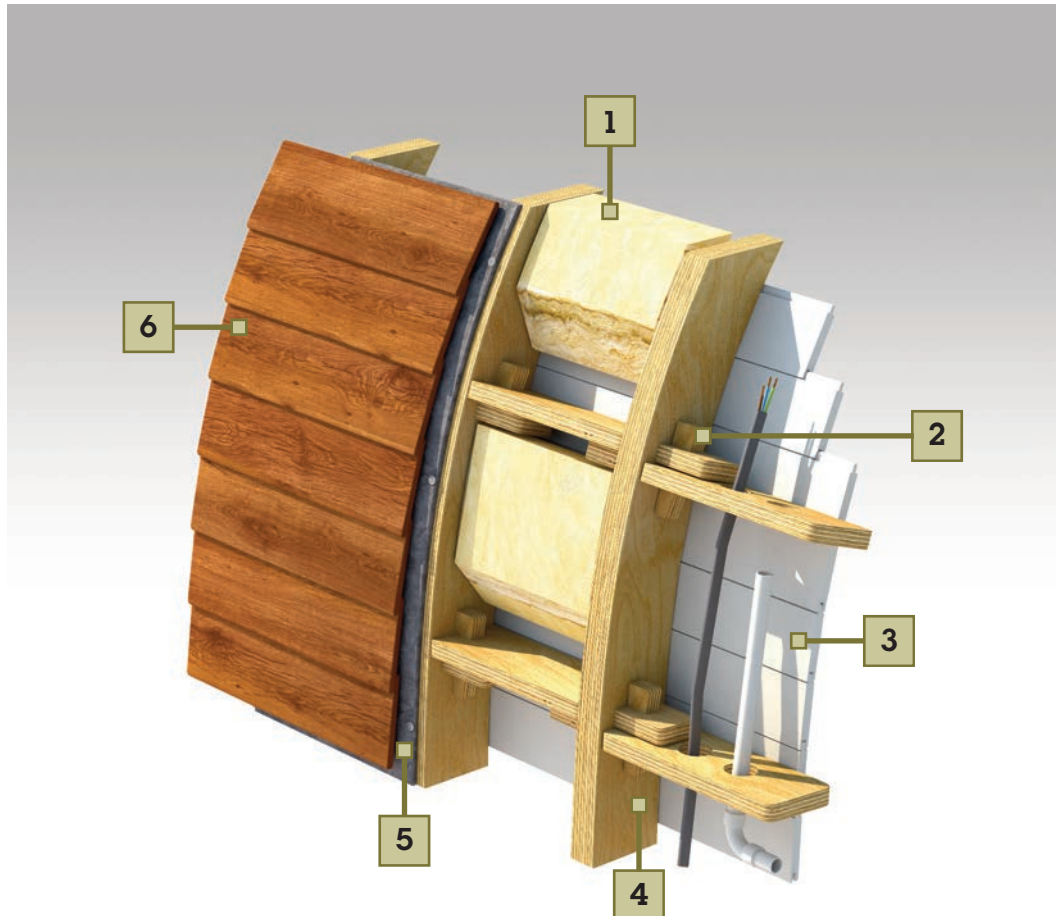

- 1** The framework cavity is insulated with a highly efficient layer of ecologically sound 100mm flexible mineral wool. The semi-rigid shape of the insulation allows it to be measured and cut accurately filling the void more completely, thereby providing excellent all year round thermal and acoustic performance.
- 2** The rigidity of the framework is compounded by the use of a tried and trusted tusk tenon and wedge jointing system, this jointing method creates a uniquely strong and versatile joint.
- 3** The interior of our Pod is lined with select grade Scandinavian redwood tongue and groove cladding. The primed and beautifully finished horizontal cladding not only adds a feeling of depth and substance to the interior, but also compounds the buildings overall structural rigidity.
- 4** The framework is constructed from a dual layer of bonded 18mm 'Grade A' structural plywood which has been sustainably sourced directly from Finland. Professionally cut from a unique CAD design by commercial CNC machinery, the precision framework design delivers a rigid and long lasting monocoque structure.
- 5** The slow grown Western Red Cedar exterior cladding used on our buildings is not only aesthetically pleasing, but it is exceptionally durable, stable and of course ethically sourced. Our Western Red Cedar cladding can be either hand oiled to preserve its rich colour or alternatively left untreated turning a muted silver grey over the seasons.
- 6** The rigidity of the framework is compounded by the use of a tried and trusted tusk tenon and wedge jointing system, this jointing method creates a uniquely strong and versatile joint.

Technical - Floors

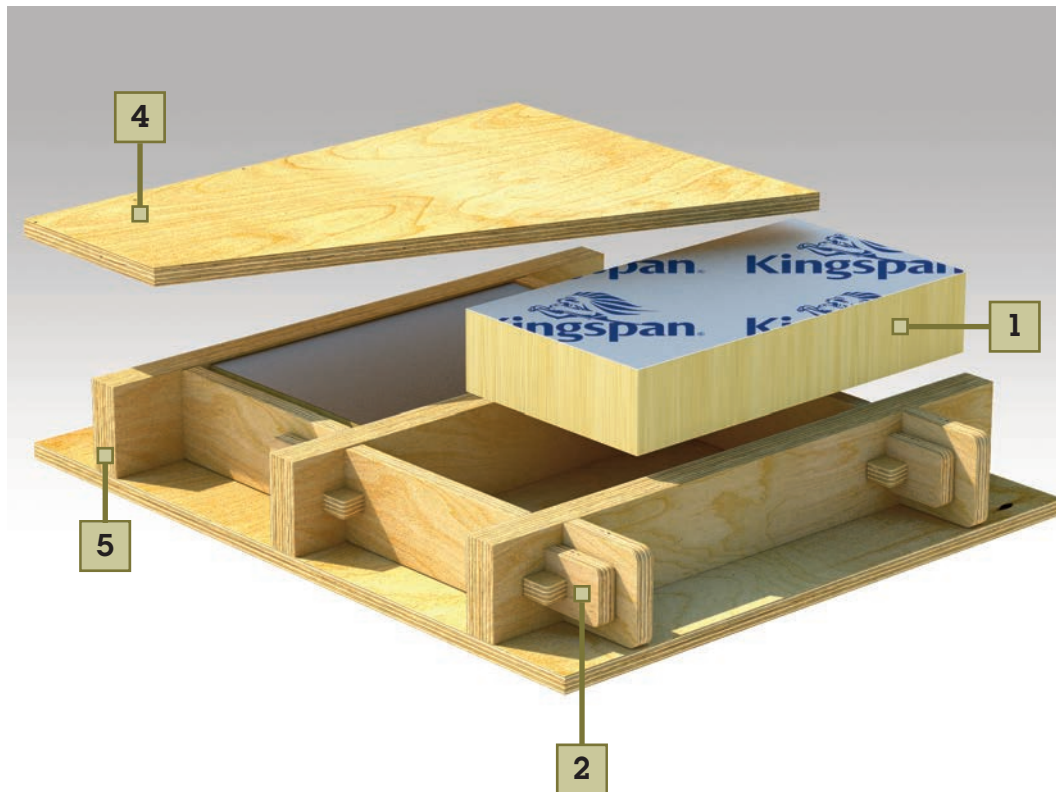

- 1 The base framework cavity is insulated with premium performance 100mm foil faced rigid insulation. The high compressive strength and water resistance of the insulation makes it ideal for the floor void, providing excellent all year round thermal performance.
- 2 The rigidity of the floor framework is compounded by the use of a tried and trusted tusk tenon and wedge jointing system, this jointing method creates a uniquely strong and versatile joint.
- 3 Constructed from a dual layer of bonded 18mm 'Grade A' structural plywood which has been sustainably sourced directly from Finland. Professionally cut from a unique CAD design by commercial CNC machinery, the precision framework design delivers a rigid and long lasting permanent base framework.
- 4 Our subfloor is constructed from exterior grade hardwood ply bonded with water resistant adhesives to create a strong, flat and rigid base layer.

Key features

All Pods from Garden Hideouts have been designed to offer a practical and attractive space that has been built for durability, warmth and weather-proofing.

Each building is constructed from a dual layer of bonded 18mm 'Grade A' structural ply. This has been sustainably sourced directly from Finland before being professionally cut from a unique CAD design on our CNC machinery. The building's precision built framework utilises the tried and trusted tusk tenon and wedge system. The result is uniquely strong series of joints, delivering a rigid, robust and long-lasting structural frame.

- **Western Red Cedar exterior cladding: ethically-sourced and slow-grown.**
Can be either hand-oiled to preserve its rich colour or left untreated to turn silver-grey over the seasons.
- **Select grade Scandinavian Redwood tongue and groove interior cladding.**
Primed, painted and immaculately finished
- **Framework cavity insulated with a layer of ecologically sound 100mm flexible mineral wool.** The semi-rigid shape of the insulation allows it to be measured and cut accurately filling the void more completely, thereby providing excellent all year round thermal and acoustic performance.
- **'A' rated double glazed bespoke wooden door and window units.**
- **Optional distinctive half-glazed end panel.**
- **Quick-Step Impressive laminate flooring with water-repellent 'Hydroseal' coating.**
- **Certified electrical system with high quality finish outlets.**
- **Fully delivered to site and professionally constructed.**

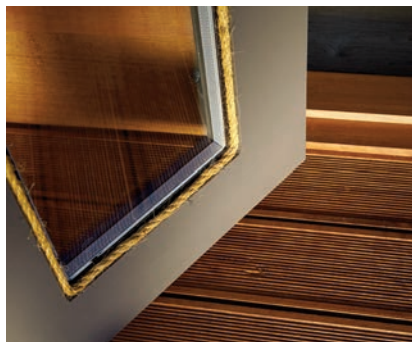
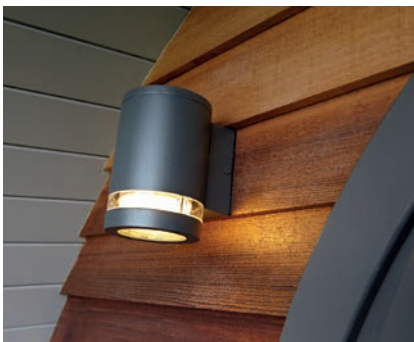

General Specification

Foundations

The most suitable type of foundation will be selected for the ground conditions where the Pod is to be sited to ensure a secure base for the building.

Framework

Walls

100mm x 36mm sustainably sourced precision cut Grade 'A' structural ply fixed at joint cross sections with a tusk tenon and wedge system.

Floor

18mm Grade 'A' quality exterior ply floor and internal subfloor.

Insulation

Walls

100mm flexible mineral wool insulation with a U-value 0.22w/m²K* installed within each natural cavity section of the framework.

Floor

100mm foil faced rigid foam insulation board with a U-value of 0.26w/m²K* installed within the floor and subfloor cavity.

External Cladding

150mm x 15mm Western Redwood Cedar featheredge boards installed with a 50mm overlap and secured with galvanised fixings over a high performance breathable vapour membrane. Hand finished with satin-matt microporous UV protection oil.

Internal Cladding

90mm x 20mm Scandinavian Redwood tongue and groove. Hand primed and painted with BS6150 compliant high quality acrylic primer and emulsion.

Electrics & Lighting

17th Edition compliant consumer unit and wiring with current Part P certification.

Doors & Windows

Tricoya wood double glazed 'A' rated toughened glass units. So hard wearing and weather resistant they come with a 50 year guarantee. Fungal resistant and super-low maintenance.

Classic Pod Specifics

Dinette

The Pullman style dinette provides a socialising and dining space for up to 4 people. The large Oak veneer table is supported by two stainless steel legs with inset cups into the floor, allowing them to be easily removed when the table is not needed. The seating is well cushioned and comfortable, upholstered in flame retardant fabric available in a number of finishes, ranging from contemporary designs to a leather option.

Double Bed

The convertible seating area quickly and ingeniously converts into a generously sized double bed when required. The table drops down to act as the bed's base whilst the seating cushions neatly convert into the mattress. It means the room can remain clutter free whether in living or sleeping mode.

Flooring

The entire floor is fitted with Quick-Step Impressive Ultra laminate flooring, which not only looks aesthetically pleasing but also has a water-repellent 'Hydroseal' coating to provide a durable, splash-proof surface.

Heating

Underfloor heating combines with high-efficiency insulation to provide a supremely warm and comfortable environment. The heating is operated via a timer unit for maximum convenience and economy.

Storage & shelving

Each seating unit has ample storage inside, ideal for bedding etc. There is additional storage in the unit accessed via a chrome handled door, along with fitted shelves. A further shelf runs along the back of each seat, ideal for display items or books. This can be painted in the colour of your choice.

There is an enclosed storage unit with oak veneer top set into the corner at the side of the entrance door, as well as storage under the matching sink unit opposite. These units can also be painted in the colour of your choice. We can even alter the cupboard shape to include a fridge.

4 floating shelves are situated above the corner units, featuring inset downlighters which illuminate the walls and create an intimate atmosphere. The shelves are ideal for ornamental and display items.

Sink

Set into a corner unit with an oak veneer top, the stainless steel bowl and tap is practical yet attractive.

Sockets

4 polished chrome 240v sockets are strategically located around the Pod.

Lighting

A classic pendant light hangs above the dinette, proving effective but unobtrusive light to the area. Additional lighting is provided by downlighters set into the ceiling as well as the atmospheric illumination from the corner shelving. The lights are controlled via double switches in a polished chrome finish.

Optional Extras

All our models are designed to a high standard specification within each range. However, because we design and construct your building from scratch you can of course request upgrades or additional items for your build. Your surveyor will be happy to talk through with you what exactly can be achieved by way of tailoring a standard specification or adding a number of additional items.

Warranties

In order that you can enjoy your building for years to come we ensure that all our models are constructed to the very highest standards using only the finest quality materials. However, in the event that you do experience any issue with your buildings construction or it's component parts, we provide the following warranty cover as standard on all our ranges, right from the date that your building is built.

25-year Full Structural Framework Warranty

The strength and integrity of your buildings framework is such, that properly maintained and protected from the elements it will remain strong and stable for years to come. Our unique 25 year structural warranty provides the ultimate peace of mind.

Full 12 months Warranty

We guarantee that our buildings will be free from any significant material defect or faulty workmanship for a period of 12 months from the date of delivery or construction. The warranty covers all workmanship, materials, standard and buyer specified fixtures and fittings, wiring and utility connections.

