



outdoor living spaces

www.gardenhideouts.co.uk



Office Pod

3mtr x 4.76mtr
from £18,950
with furniture £20,950

4mtr x 4.76mtr
from £23,950
with furniture £25,950

Available unfurnished from £14,950

Derby Office
Mercia Marina, Findern Lane, Willington,
Derbyshire DE65 6DW
t: 01283 707357

Hanbury Office
Hanbury Wharf, Hanbury Road, Droitwich,
Worcester WR9 7DU
t: 01905 794445

Office Pod

The Office Pod from Garden Hideouts is the ideal solution for the home worker who needs their own productive space, or for any business that is looking for a simple, modern way to provide more office space with no planning permission required.

Versatile enough to accommodate a small meeting, the Office Pod has been carefully designed to maximise your efficiency whilst also providing a very stylish contemporary environment that helps make working a pleasure and gives a good impression to any visitors.

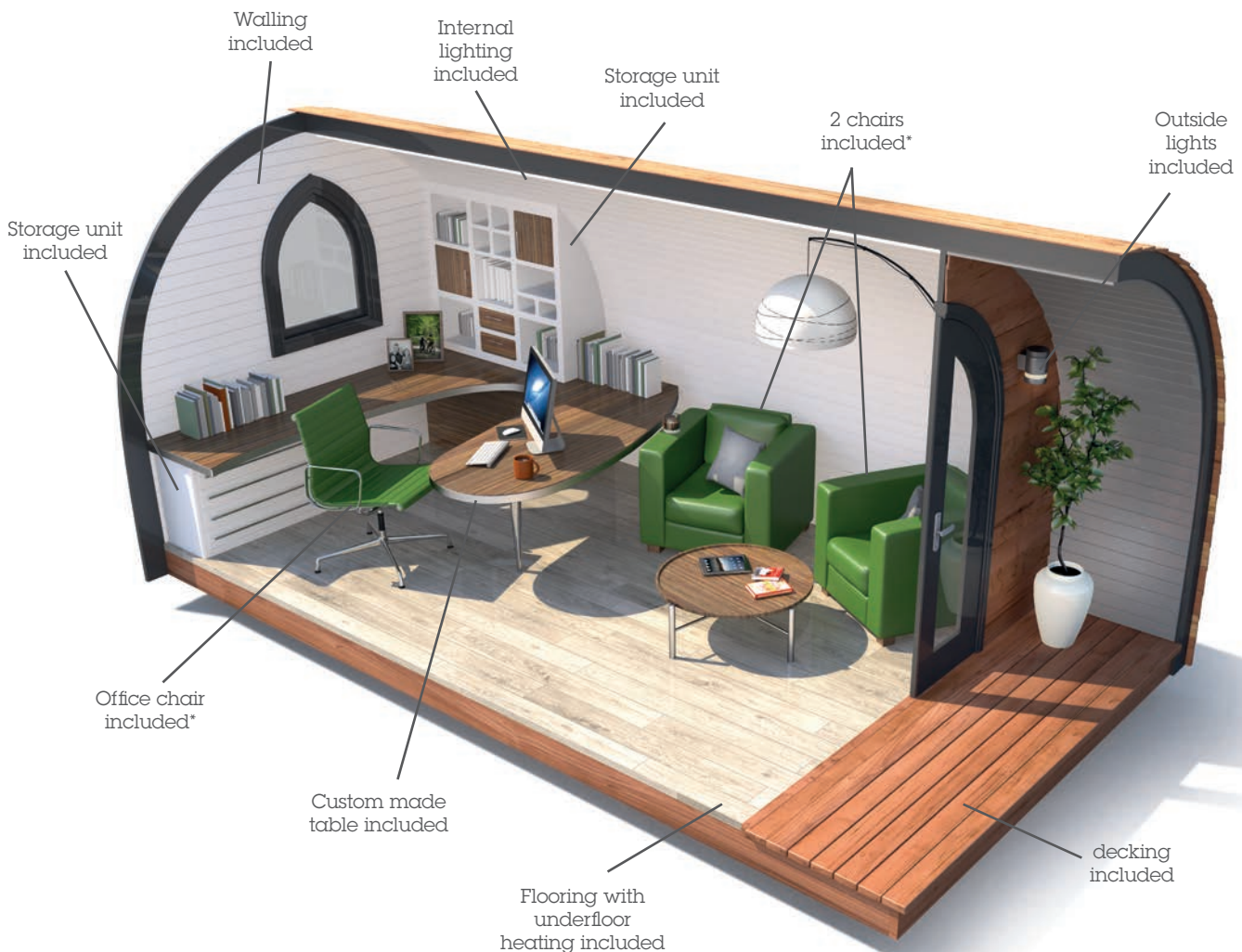

3mtr x 4.76mtr
from £18,950
with furniture £20,950

4mtr x 4.76mtr
from £23,950
with furniture £25,950

Available unfurnished from £14,950

*Examples shown for visual purposes only.

3mtr Plans

External

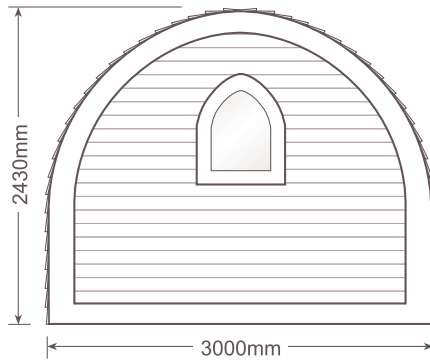
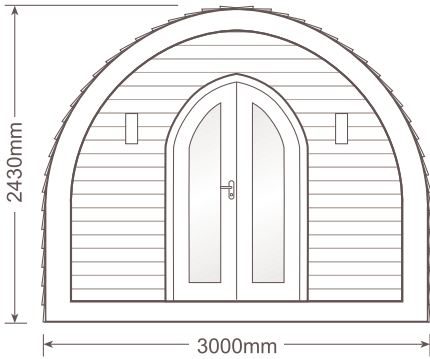

Dimensions*

External Width: 3000mm Internal Width: 2720mm
External Length: 4760mm Internal Length: 3440mm
External Height: 2430mm Internal Height: 2160mm

External Deck Area: 900mm x 2760mm
Door Dimensions: 1760mm x 1000mm
Window Dimensions: 850mm x 680mm

Internal Floor Area: 9.96m²

Internal

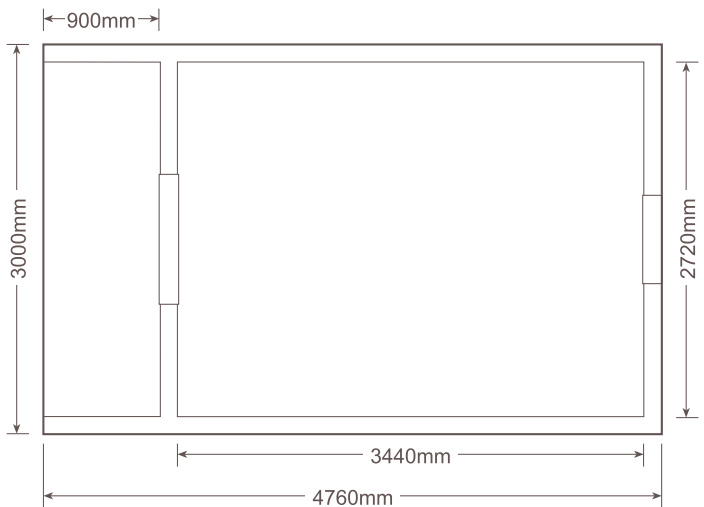
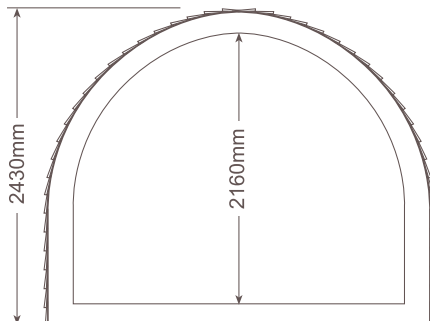

*Sizes are approximate, as these are hand crafted products measurements may vary.

4mtr Plans

External

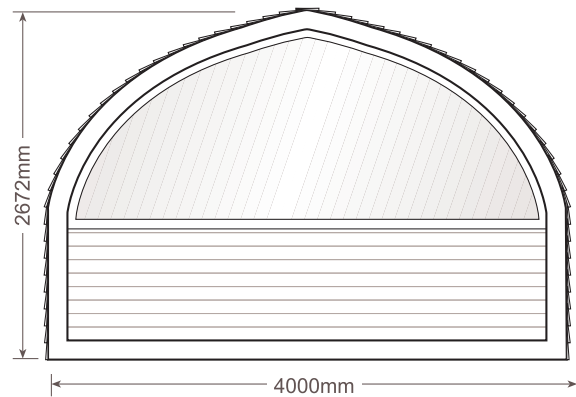
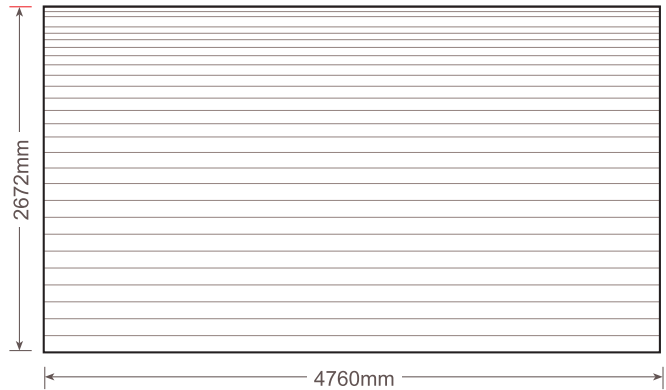
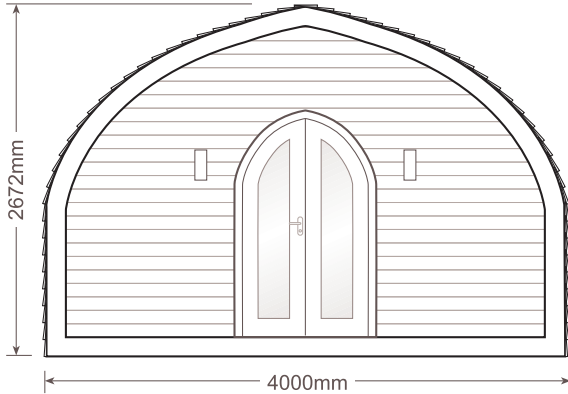

Dimensions*

External Width: 4000mm Internal Width: 3720mm
External Length: 4760mm Internal Length: 3440mm
External Height: 2672mm Internal Height: 2402mm

External Deck Area: 900mm x 3760mm
Door Dimensions: 1760mm x 1000mm
Window Dimensions: 1350mm x 3500mm

Internal Floor Area: 12.80m²

Internal

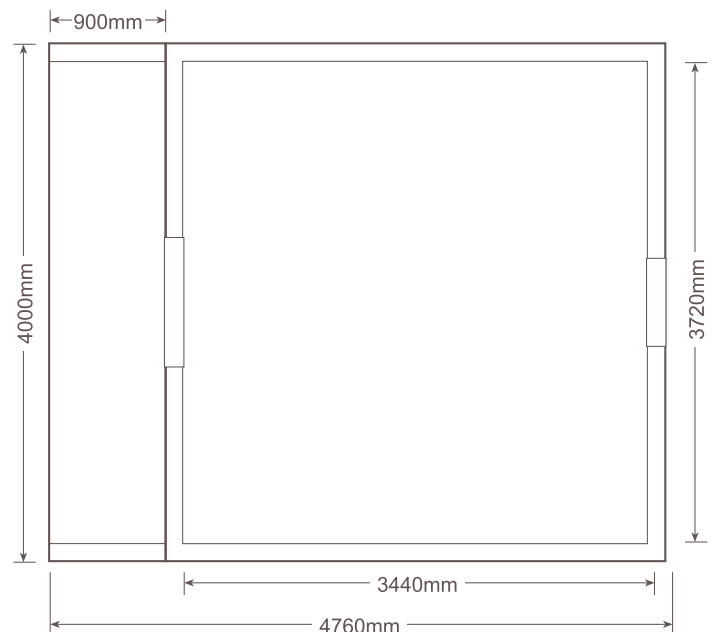
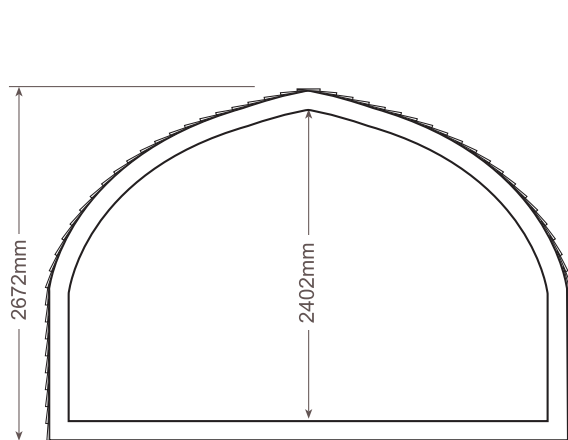

*Sizes are approximate, as these are hand crafted products measurements may vary.

Technical - Walls

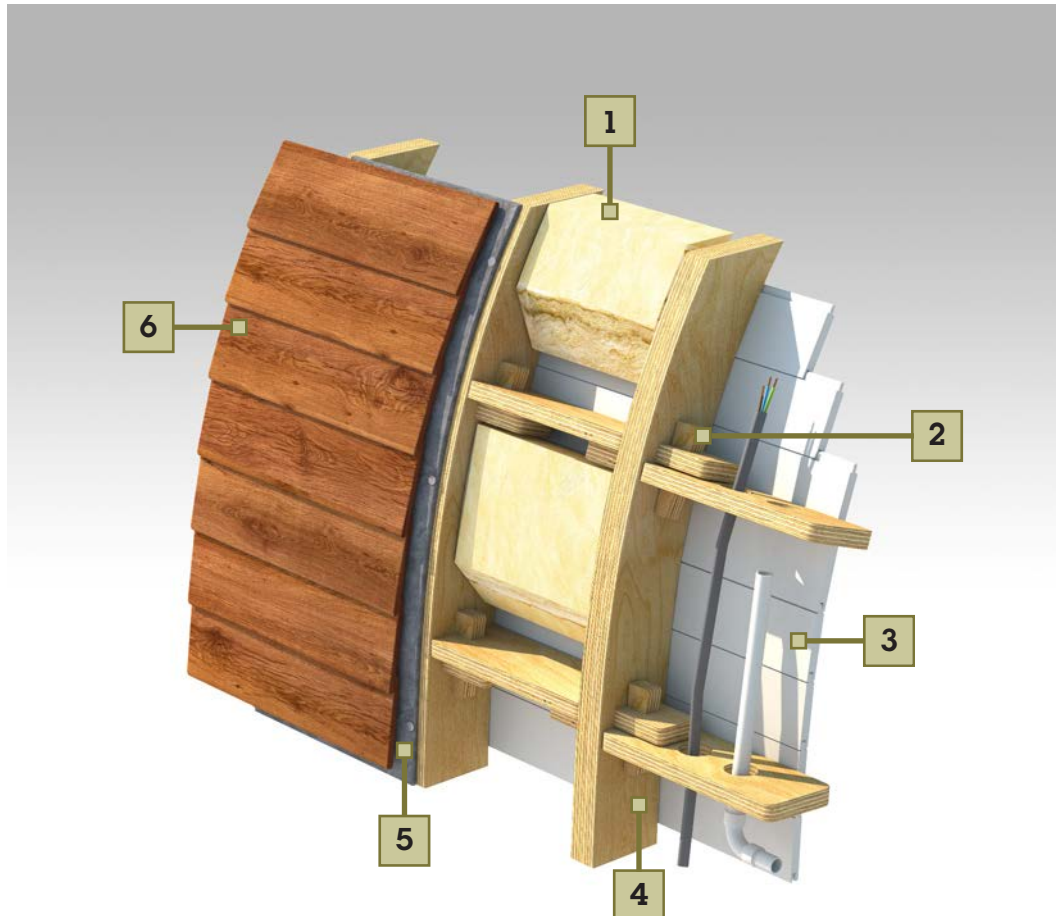

- 1** The framework cavity is insulated with a highly efficient layer of ecologically sound 100mm flexible mineral wool. The semi-rigid shape of the insulation allows it to be measured and cut accurately filling the void more completely, thereby providing excellent all year round thermal and acoustic performance.
- 2** The rigidity of the framework is compounded by the use of a tried and trusted tusk tenon and wedge jointing system, this jointing method creates a uniquely strong and versatile joint.
- 3** The interior of our Pod is lined with select grade Scandinavian redwood tongue and groove cladding. The primed and beautifully finished horizontal cladding not only adds a feeling of depth and substance to the interior, but also compounds the buildings overall structural rigidity.
- 4** The framework is constructed from a dual layer of bonded 18mm 'Grade A' structural plywood which has been sustainably sourced directly from Finland. Professionally cut from a unique CAD design by commercial CNC machinery, the precision framework design delivers a rigid and long lasting monocoque structure.
- 5** The slow grown Western Red Cedar exterior cladding used on our buildings is not only aesthetically pleasing, but it is exceptionally durable, stable and of course ethically sourced. Our Western Red Cedar cladding can be either hand oiled to preserve its rich colour or alternatively left untreated turning a muted silver grey over the seasons.
- 6** The rigidity of the framework is compounded by the use of a tried and trusted tusk tenon and wedge jointing system, this jointing method creates a uniquely strong and versatile joint.

Technical - Floors

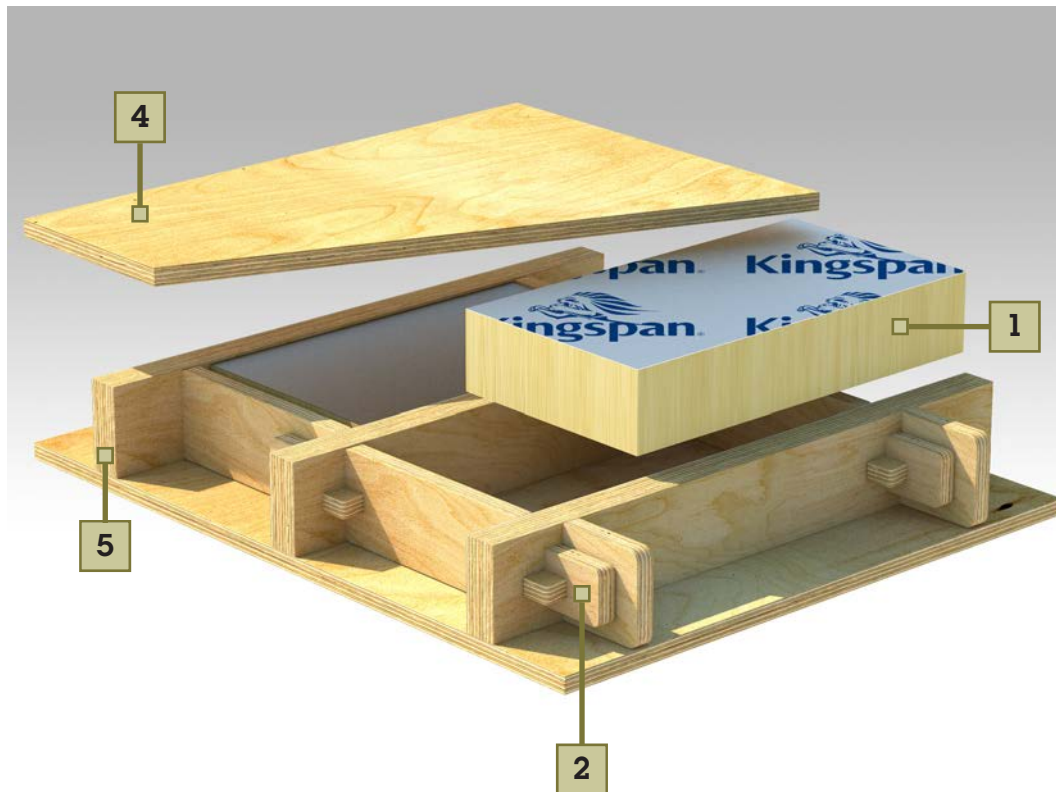

- 1 The base framework cavity is insulated with premium performance 100mm foil faced rigid insulation. The high compressive strength and water resistance of the insulation makes it ideal for the floor void, providing excellent all year round thermal performance.
- 2 The rigidity of the floor framework is compounded by the use of a tried and trusted tusk tenon and wedge jointing system, this jointing method creates a uniquely strong and versatile joint.
- 3 Constructed from a dual layer of bonded 18mm 'Grade A' structural plywood which has been sustainably sourced directly from Finland. Professionally cut from a unique CAD design by commercial CNC machinery, the precision framework design delivers a rigid and long lasting permanent base framework.
- 4 Our subfloor is constructed from exterior grade hardwood ply bonded with water resistant adhesives to create a strong, flat and rigid base layer.

Key features

All Pods from Garden Hideouts have been designed to offer a practical and attractive space that has been built for durability, warmth and weather-proofing.

Each building is constructed from a dual layer of bonded 18mm 'Grade A' structural ply. This has been sustainably sourced directly from Finland before being professionally cut from a unique CAD design on our CNC machinery. The building's precision built framework utilises the tried and trusted tusk tenon and wedge system. The result is uniquely strong series of joints, delivering a rigid, robust and long-lasting structural frame.

- **Western Red Cedar exterior cladding: ethically-sourced and slow-grown.**
Can be either hand-oiled to preserve its rich colour or left untreated to turn silver-grey over the seasons.
- **Select grade Scandinavian Redwood tongue and groove interior cladding.**
Primed, painted and immaculately finished
- **Framework cavity insulated with a layer of ecologically sound 100mm flexible mineral wool.** The semi-rigid shape of the insulation allows it to be measured and cut accurately filling the void more completely, thereby providing excellent all year round thermal and acoustic performance.
- **'A' rated double glazed bespoke wooden door and window units.**
- **Optional distinctive half-glazed end panel.**
- **Quick-Step Impressive laminate flooring with water-repellent 'Hydroseal' coating.**
- **Certified electrical system with high quality finish outlets.**
- **Fully delivered to site and professionally constructed.**

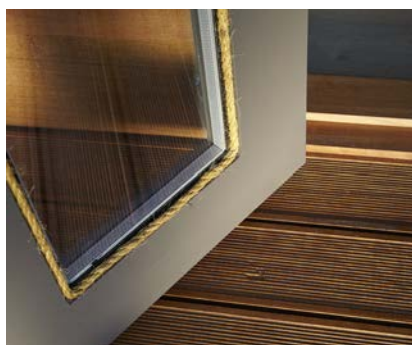
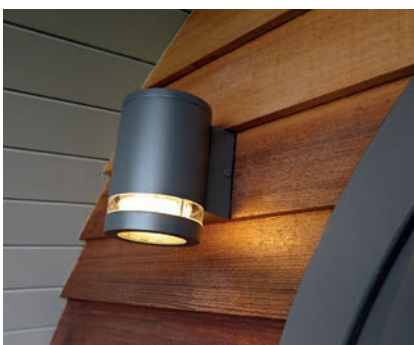

General Specification

Foundations

The most suitable type of foundation will be selected for the ground conditions where the Pod is to be sited to ensure a secure base for the building.

Framework

Walls

100mm x 36mm sustainably sourced precision cut Grade 'A' structural ply fixed at joint cross sections with a tusk tenon and wedge system.

Floor

18mm Grade 'A' quality exterior ply floor and internal subfloor.

Insulation

Walls

100mm flexible mineral wool insulation with a U-value 0.22w/m²K* installed within each natural cavity section of the framework.

Floor

100mm foil faced rigid foam insulation board with a U-value of 0.26w/m²K* installed within the floor and subfloor cavity.

External Cladding

150mm x 15mm Western Redwood Cedar featheredge boards installed with a 50mm overlap and secured with galvanised fixings over a high performance breathable vapour membrane. Hand finished with satin-matt microporous UV protection oil.

Internal Cladding

90mm x 20mm Scandinavian Redwood tongue and groove. Hand primed and painted with BS6150 compliant high quality acrylic primer and emulsion.

Electrics & Lighting

17th Edition compliant consumer unit and wiring with current Part P certification.

Doors & Windows

Tricoya wood double glazed 'A' rated toughened glass units. So hard wearing and weather resistant they come with a 50 year guarantee. Fungal resistant and super-low maintenance.

Office Pod Specifics

Workstation

The standard desk is a design that is visually impactful but also very practical. The full wraparound structure is of 18mm birch ply with a bullnose edge which has been sanded and varnished to leave the layers of laminate visible. This gives it a very substantial, contemporary look. To maximise the space underneath the desk it is supported on a stainless steel leg.

There is also a desk upgrade available which comprises a solid hardwood option. The design and location of this desk enables it to double-up as a meeting table with space to seat two clients. When this desk is selected the theme of the office is changed to Walnut throughout.

Storage

A pigeon-hole unit is easily to hand, sitting on top of the desk and following the curve of the building. Deep enough to house files and A4 stationery, this unit is perfect for storing letters and sundry items in the open pigeon-holes and also has three units with doors.

Behind the seating position are two stylish filing cabinet units, each with two drawers containing suspension racking.

Floorcoverings

The entire floor is fitted with Quick-Step Impressive laminate flooring, which not only looks aesthetically pleasing but also has a water-repellent 'Hydrosed' coating to provide a durable surface.

Heating

Underfloor heating combines with high-efficiency insulation to provide a supremely warm and comfortable environment. The heating is operated via a timer unit for maximum convenience and economy.

Lighting

The standard lighting is a set of downlighters that provide ample but discreet illumination. There is also the option for decorative wall lights, front and back, which have a uniquely attractive effect on the appearance and atmosphere of the room.

Sockets

Polished chrome 240v sockets are spaced around the Pod to suit specific needs. All sockets come complete with a USB adapter..

Optional Extras

All our models are designed to a high standard specification within each range. However, because we design and construct your building from scratch you can of course request upgrades or additional items for your build. Your surveyor will be happy to talk through with you what exactly can be achieved by way of tailoring a standard specification or adding a number of additional items.

Warranties

In order that you can enjoy your building for years to come we ensure that all our models are constructed to the very highest standards using only the finest quality materials. However, in the event that you do experience any issue with your buildings construction or it's component parts, we provide the following warranty cover as standard on all our ranges, right from the date that your building is built.

25-year Full Structural Framework Warranty

The strength and integrity of your buildings framework is such, that properly maintained and protected from the elements it will remain strong and stable for years to come. Our unique 25 year structural warranty provides the ultimate peace of mind.

Full 12 months Warranty

We guarantee that our buildings will be free from any significant material defect or faulty workmanship for a period of 12 months from the date of delivery or construction. The warranty covers all workmanship, materials, standard and buyer specified fixtures and fittings, wiring and utility connections.

